

MULTI PURPOSE SERIES



Valve Regulated Battery Designed for Uninterruptable Power Supply (UPS), Emergency Lighting, Communication, General Purpose and Other Float Service Applications.

MPS12-75 **VALVE REGULATED** **LEAD ACID BATTERY** **FOR STANDBY POWER** **APPLICATIONS** **12V 75.0 AH @ 20 HR** **RATE, 12V 250 WATTS/** **CELL @ 15 MIN RATE**

FEATURES

- Robust plate for extended life.
- Flame-arresting one-way pressure-relief vent for safety and long life.
- Durable polypropylene container and cover.
- Thermally welded case-to-cover bond to eliminate leakage.
- Absorbent Glass Mat (AGM) technology for efficient gas recombination of up to 99% and freedom from electrolyte maintenance.
- UL-recognized component.
- Multicell design for economy of installation and maintenance.
- Can be used in any orientation. Upright, side, or end mounting recommended.
- Not restricted for air transport – Complies with IATA/ICAO Special Provision A67.
- Not restricted for surface transport – classified as non-hazardous material as related to DOT-CFR Title 49 parts 171-189.
- Not restricted for water transport – classified as non-hazardous material per IMDG Amendment 27.
- Computer designed lead, low calcium alloy grid for minimal gassing and ease of recycling.

12 Volts – 75 Ampere Hour Capacity @ 20 Hour Rate

Ampere Hour Capacity to 1.75 Volts per Cell @ 77°F (25°C)

Discharge in Hours	1.00	2.00	3.00	4.00	5.00	6.00	7.00	8.00	10.00	12.00	20.00	24.00	72.00	100.00
Amp-Hr Capacity	49.0	56.0	59.7	62.1	64.0	66.0	67.3	69.0	71.0	72.1	75.0	75.5	77.4	78.0

C&D Technologies, Inc.
DYNASTY Division
900 East Keefe Avenue
Milwaukee, WI 53212
Phone: 800-396-2789
Fax: 414-961-6506



MPS12-75

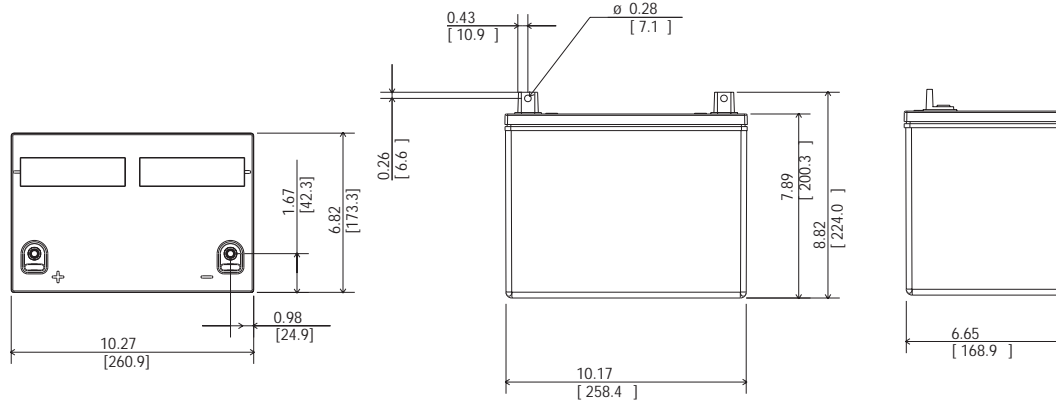

*All dimensions in inches and (millimeters). All dimensions are for reference only. Contact a C&D Representative for complete dimensional information.

MPS12-75 - Specifications

Cells Per Unit	Voltage Per Unit	Weight	Electrolyte	Maximum Discharge Current	Short Circuit Current	Ohms Imped. 60 Hz (Ω)
6	12.84	54 lbs. 25 kg	Absorbed H ₂ SO ₄ SG = 1.300	600 Amps	3100 Amps @ 0.1 sec.	0.0050 Ohms
Capacity		250 watts per cell at the 15 minute rate to 1.67 volts per cell at 77° F (25° C). 75.0 Ah @ 20 hr. rate to 1.75 volts per cell @ 77° F (25° C) 67.8 Ah @ 10 hr rate to 1.80 volts per cell @ 20° C (68° F)				
Operating Temperature Range		Discharge: -40° F (-40° C) to +160° F (71° C), Charge: -10° F (-23° C) to +140° F (60° C) (with temperature compensation)				
Recommended Operating Temperature Range		+74° F (23° C) to +80° F (27° C)				
Float Charging Voltage		13.5 to 13.8 VDC/unit Average at 77° F (25° C).				
Recommended Maximum Charging Current Limit		C/5 amperes (15.0 amperes @ 100% depth of discharge) @ 20 hour rate				
Equalization and Cycle Service Charging Voltage		14.4 to 14.8 VDC/unit Average at 77° F (25° C).				
Maximum AC Ripple (Charger)		0.5% RMS or 1.5% P-P of float charge voltage recommended for best results. Maximum AC ripple voltage allowed = (4% P-P) Maximum AC ripple current allowed = 3.75 amperes rms (C/20)				
Self Discharge		DynastyMPS batteries may be stored for up to 6 months at 77° F (25° C) and then a freshening charge is required. For higher temperatures the time interval will be shorter.				
Accessories		Inter unit connectors, racks and cabinet systems are available.				
Terminal		"L" terminal with 0.28" clearance hole to accept 0.25" (6mm) bolt.				
Terminal Hardware Initial Torque		40 in.-lbs. (4.5 n-m).				
Terminal Hardware Annual Retorque		32 in.-lbs. (3.48 n-m).				

Constant Power Discharge Ratings - Watts Per Cell @ 77°F (25°C)

Operating Time to End Point Voltage (in minutes)

End Point Volts/Cell	5	10	15	20	30	40	45	50	60	90
1.75	390	290	235	195	155	129	118	109	93.0	64.0
1.70	420	310	245	205	160	131	120	110	94.0	65.0
1.67	430	315	250	207	161	132	121	110	94.5	65.3
1.65	440	318	252	209	162	133	122	111	95.0	65.6
1.60	450	324	254	210	163	134	123	112	96.0	66.0

Constant Current Discharge Ratings - Amperes @ 77°F (25°C)

Operating Time to End Point Voltage (in hours)

End Point Volts/Cell	.083	.25	.50	.75	1	2	3	5	8	10	12	20	24	72	100
1.90	126	90.0	61.0	50.0	39.0	24.2	17.3	11.6	7.75	6.40	5.42	3.29	2.75	0.94	0.69
1.85	161	110	70.0	56.7	43.5	25.5	18.3	12.1	8.05	6.60	5.59	3.50	2.94	1.02	0.74
1.80	190	121	77.0	62.0	47.0	27.0	19.3	12.6	8.39	6.92	5.86	3.67	3.08	1.06	0.77
1.75	212	131	81.0	65.0	49.0	28.0	19.9	12.8	8.63	7.10	6.01	3.75	3.15	1.08	0.78

Note: Batteries to be mounted with 0.5 in. (1.25 cm) spacing minimum and free air ventilation. Specifications subject to change without notification.